

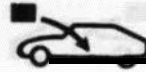

15

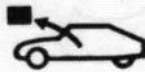

XM
961-3/1

1

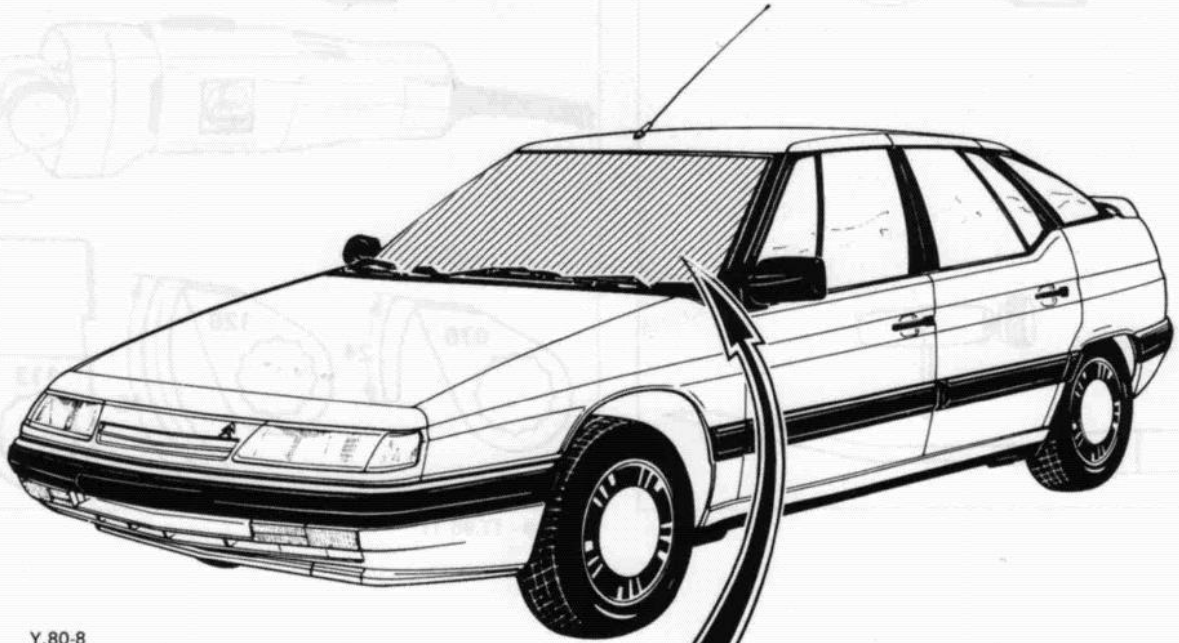

Y.80-8

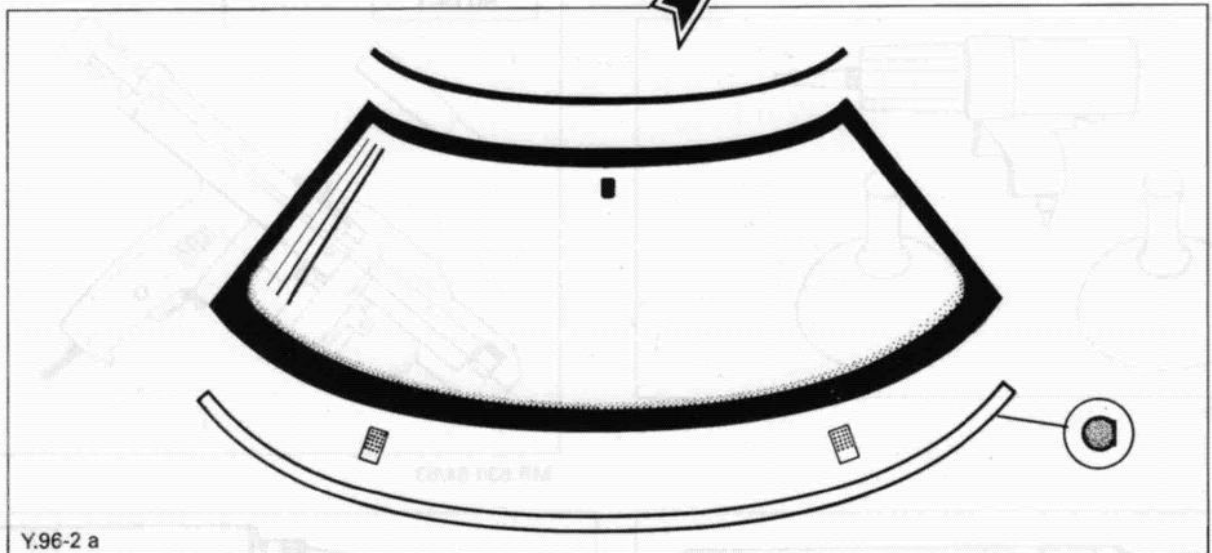

Y.96-2 a

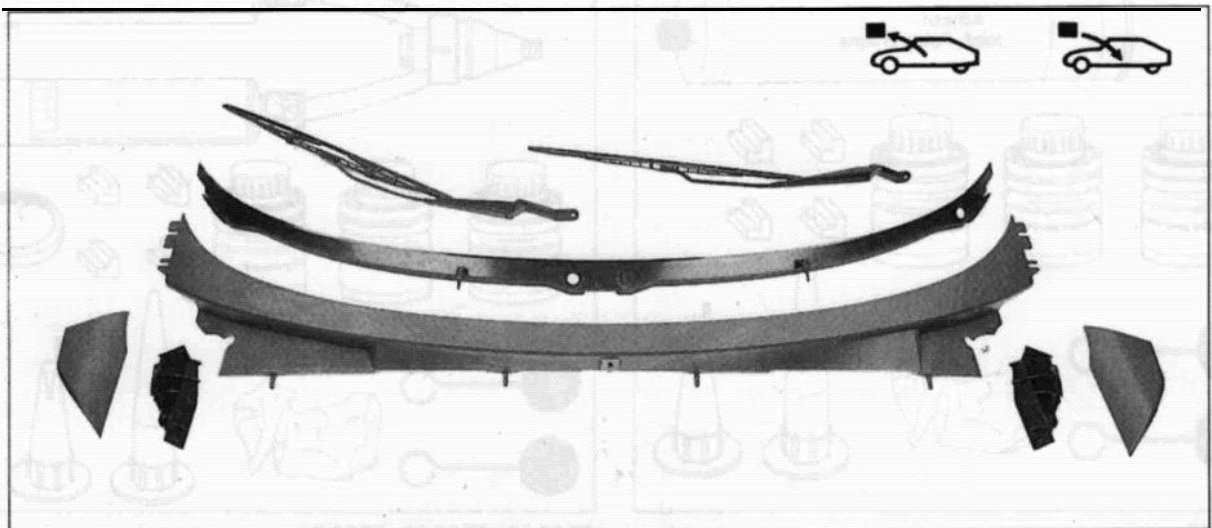

89-67

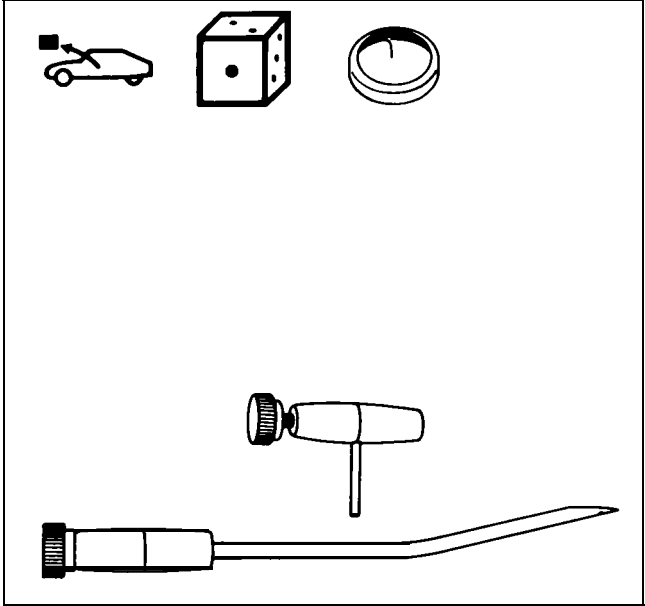
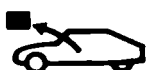

TT.96-7

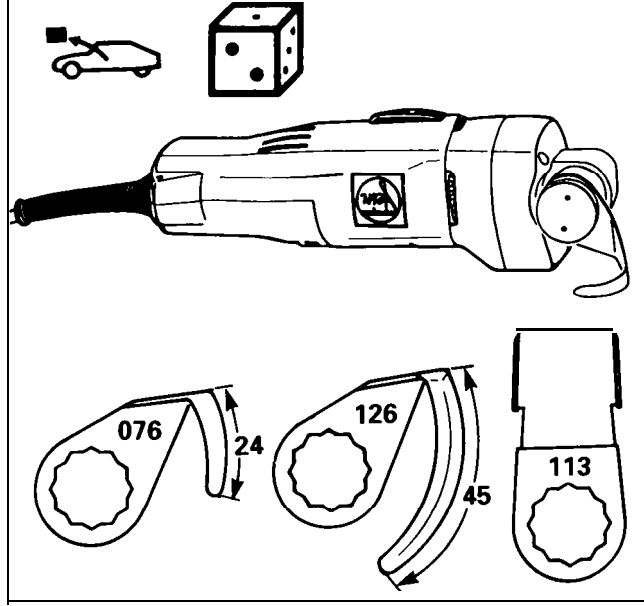

TT.96-9 - TT.96-11

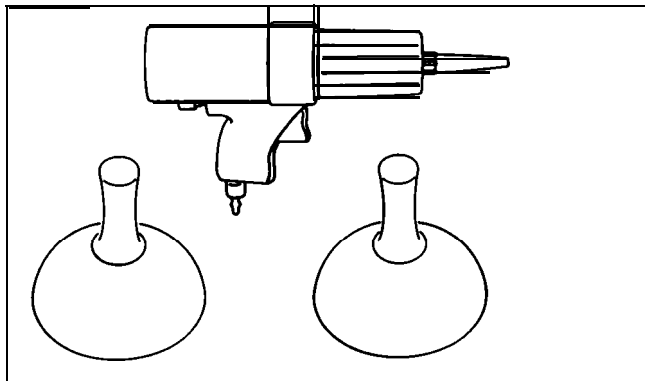

TT.96-7

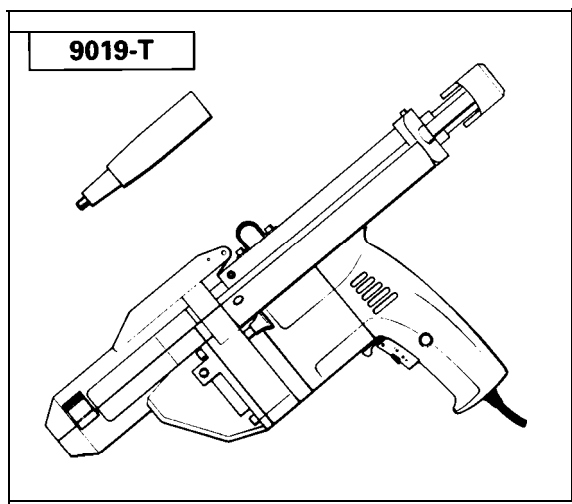

MR.630-84/53

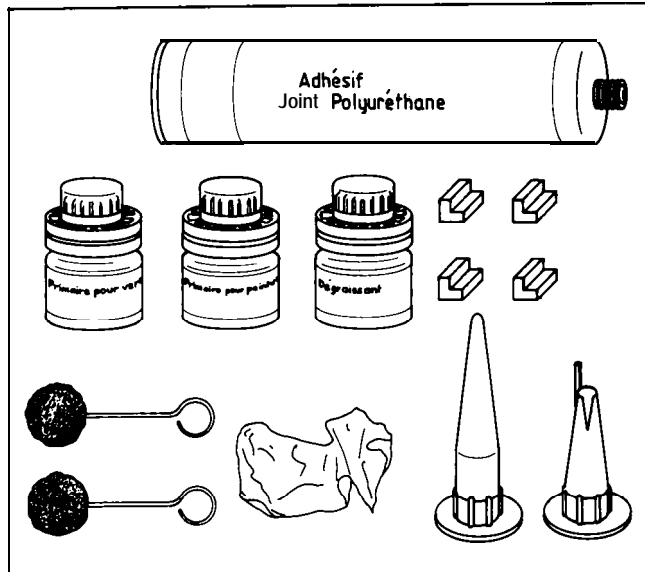

TT.96-10

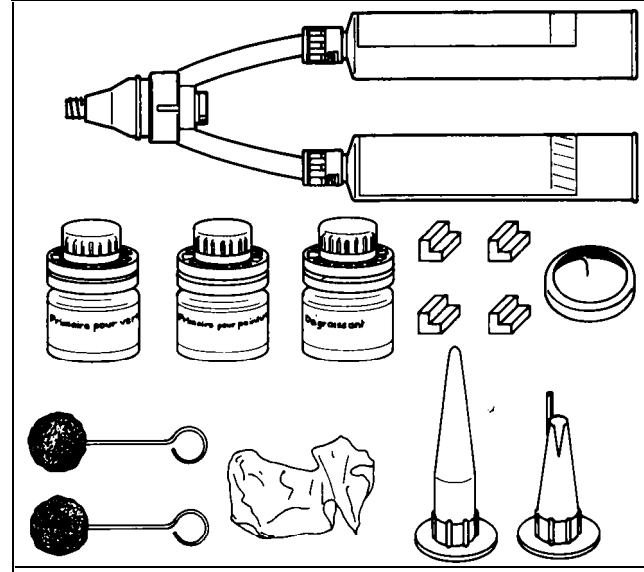

TT.96-10 - TT.96-12 - TT.96-7



15

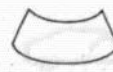
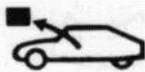

XM
961-3/1

3

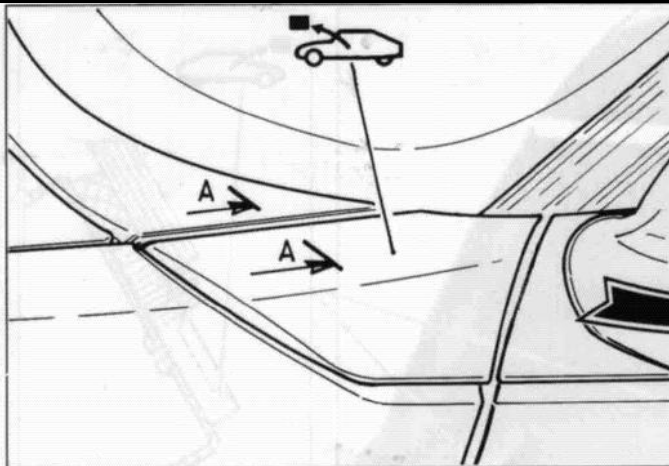

Y.96-4 a

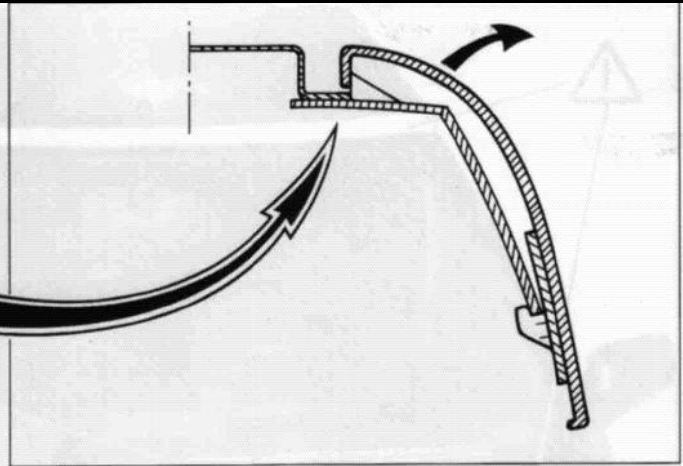

Y.96-4

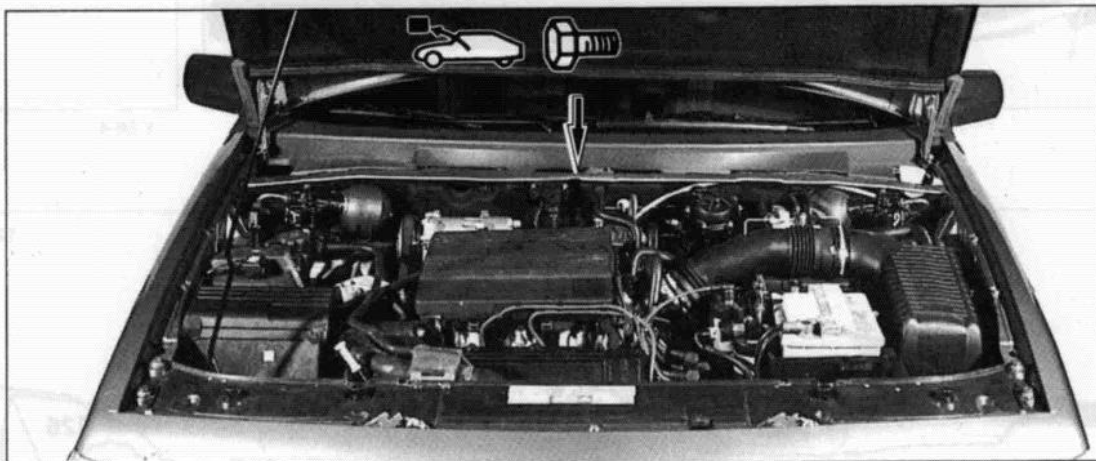

88-528

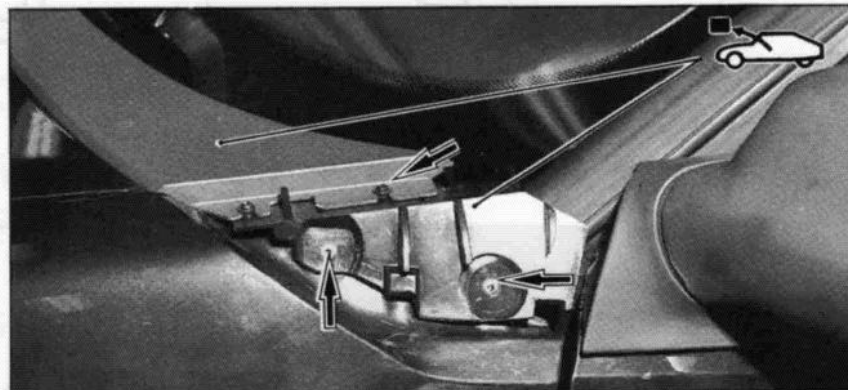

89-219

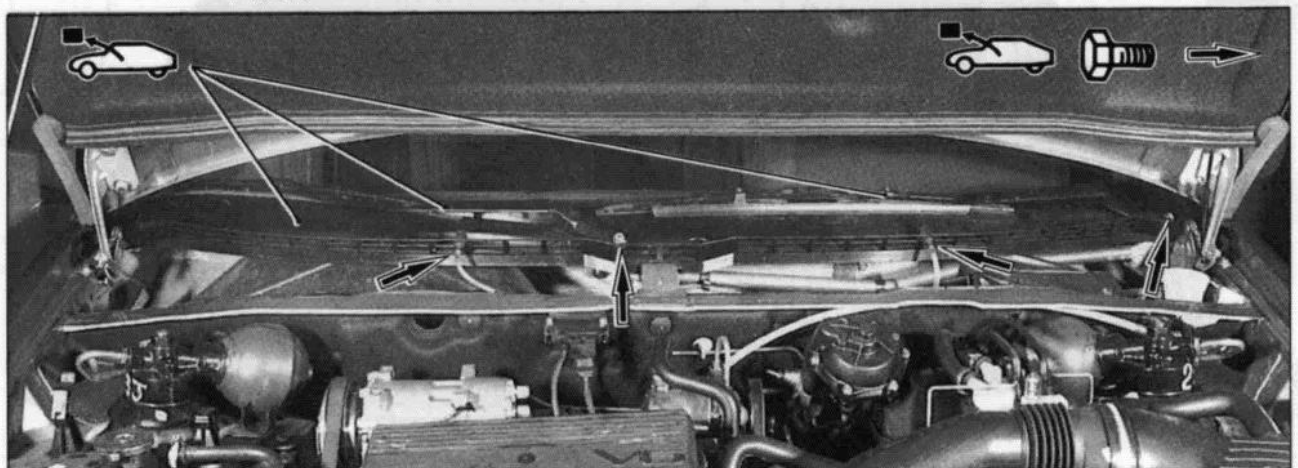

88-529

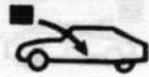
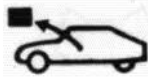

88-532

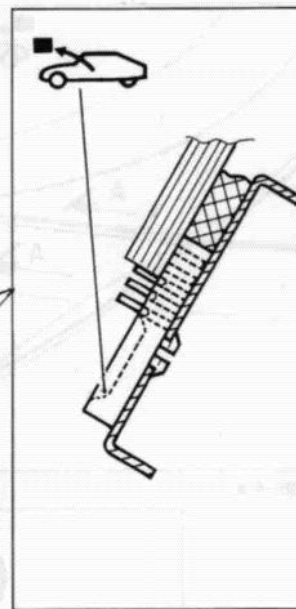

Y.96-4

TT.96-9

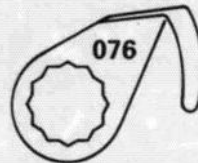
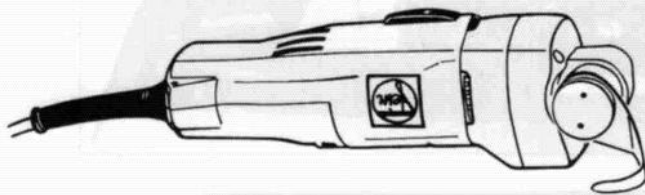

TT.96-11

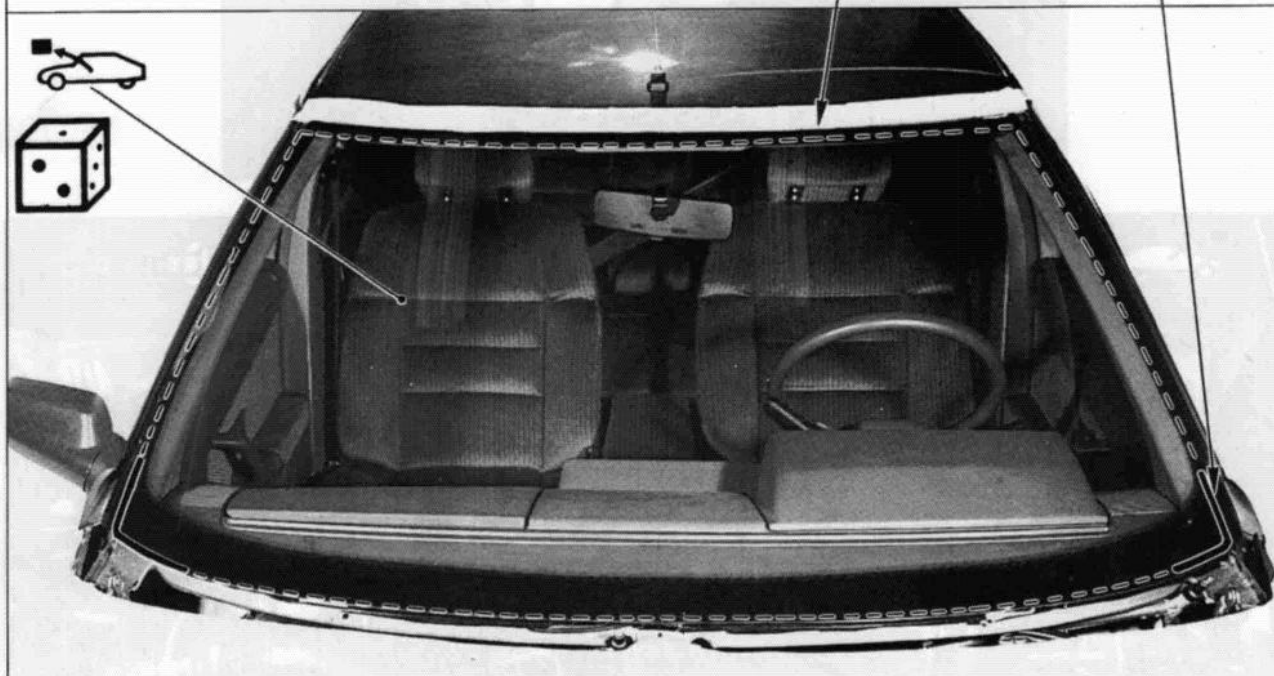
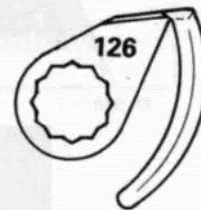

88-532



15

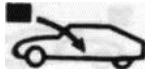
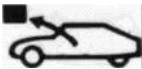

XM
961-3/1

5

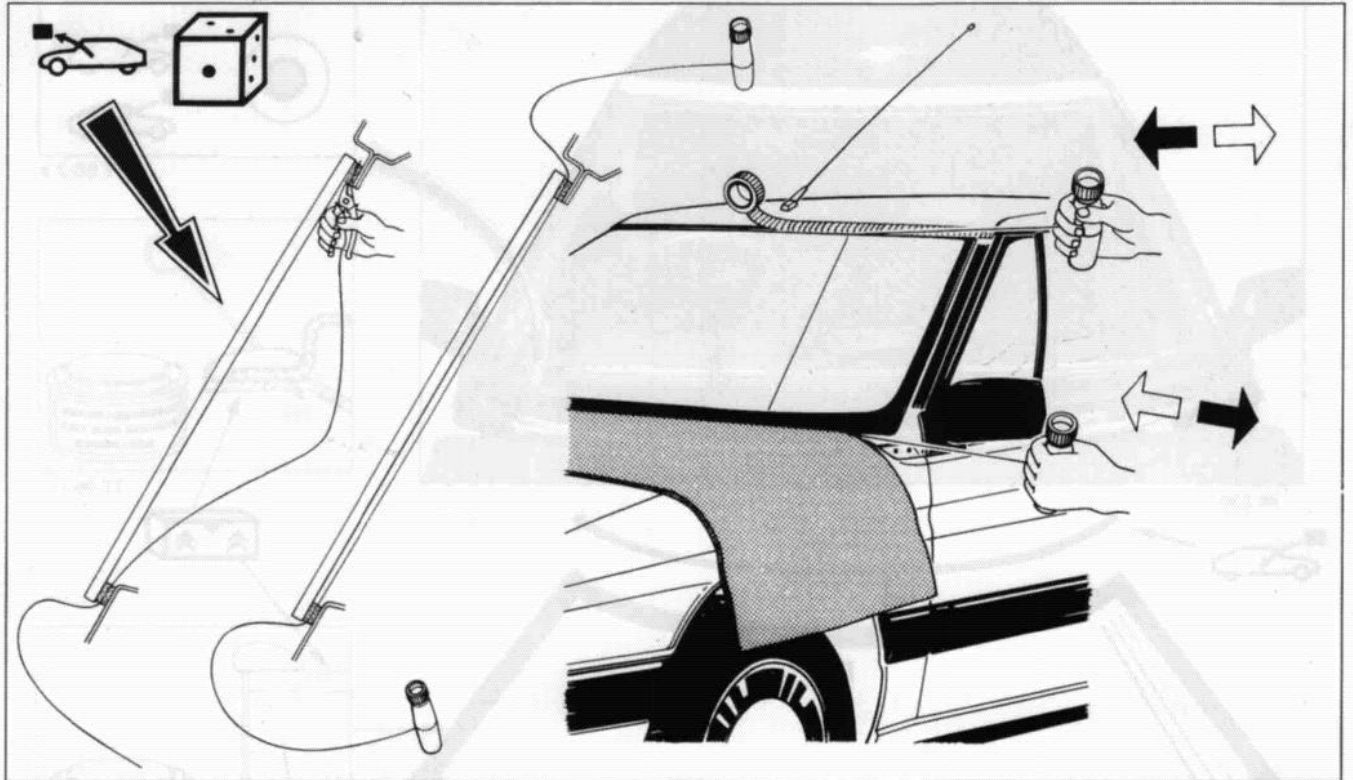

Y.96-3

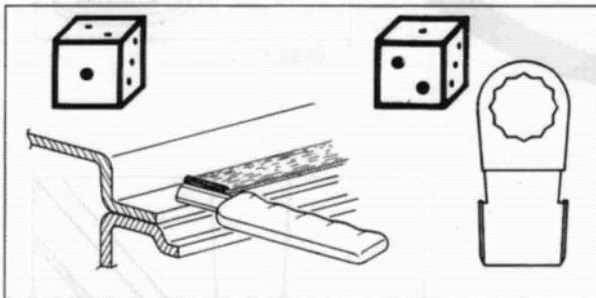

Z.96-4

TT.96-9

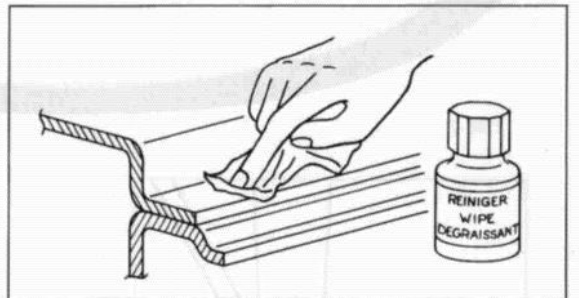

Z.96-4



88-530

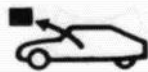

88-530

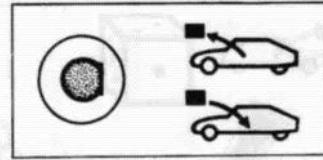

Y.96-2 a

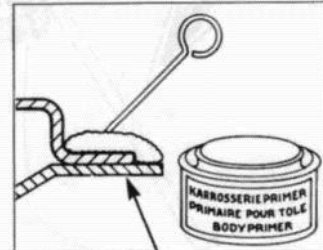

TT.96-1

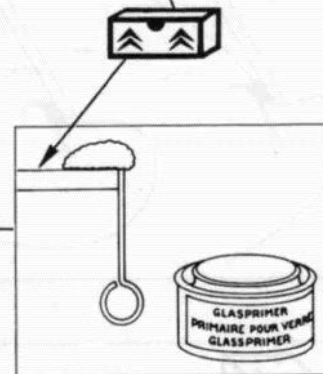

TT.96-1

Y.96-2

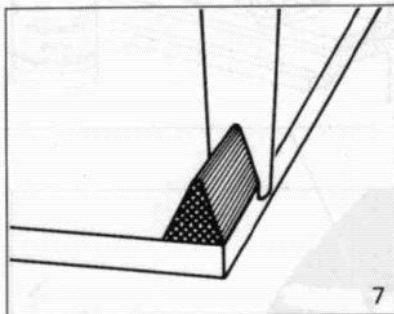

Y.96-5

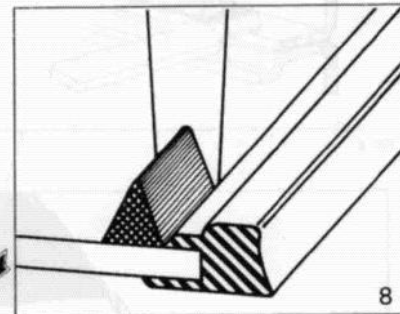

Y.96-5

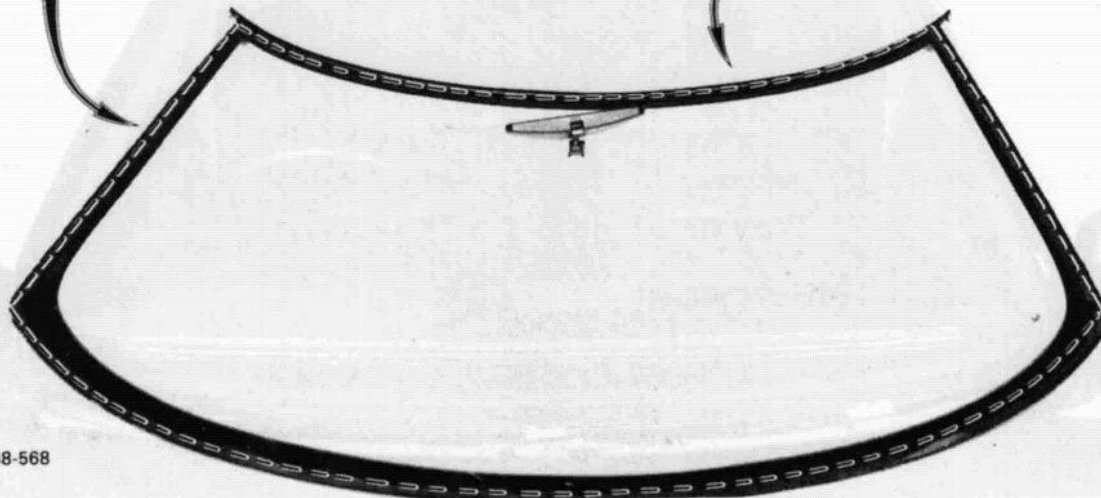

88-568



15



XM
961-3/1

7



88-530

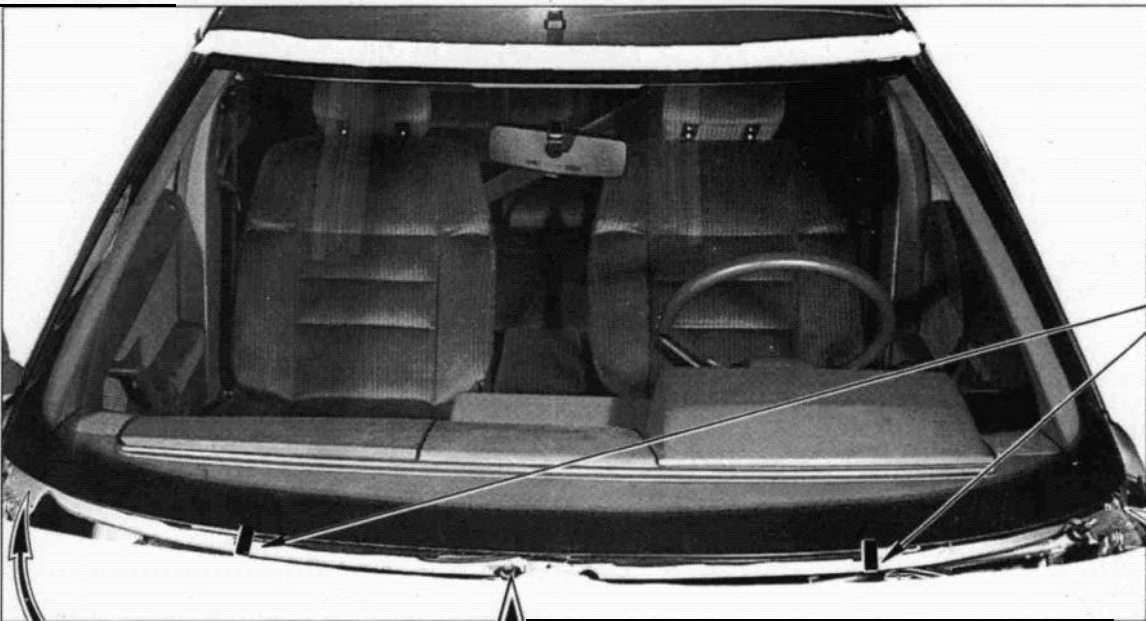

88-532

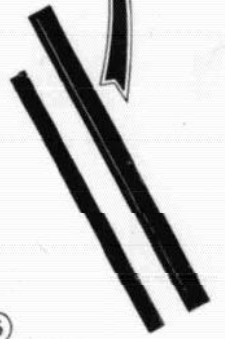
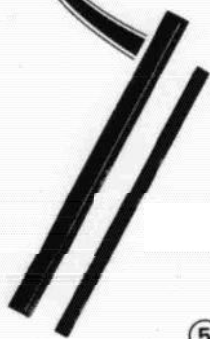

- 1 - 2 - 3

